

OVER 30 YEARS  
MANUFACTURING

 **SUPERIOR  
WATER TANKS**



WIDEST RANGE OF RAINWATER TANKS AVAILABLE!



# How to Install Your Rainwater Tank.

By

John Kean

**SUPERIOR WATER TANKS** - The Leaders in Water Tank Technology

20 Tamborine St,  
JIMBOOMBA  
Qld 4280

Phone: (07) 5546 0292  
Fax: (07) 5546 0074  
Local call: 1300 888 015

web: [www.superiorwatertanks.com.au](http://www.superiorwatertanks.com.au)  
Email: [info@superiorwatertanks.com.au](mailto:info@superiorwatertanks.com.au)

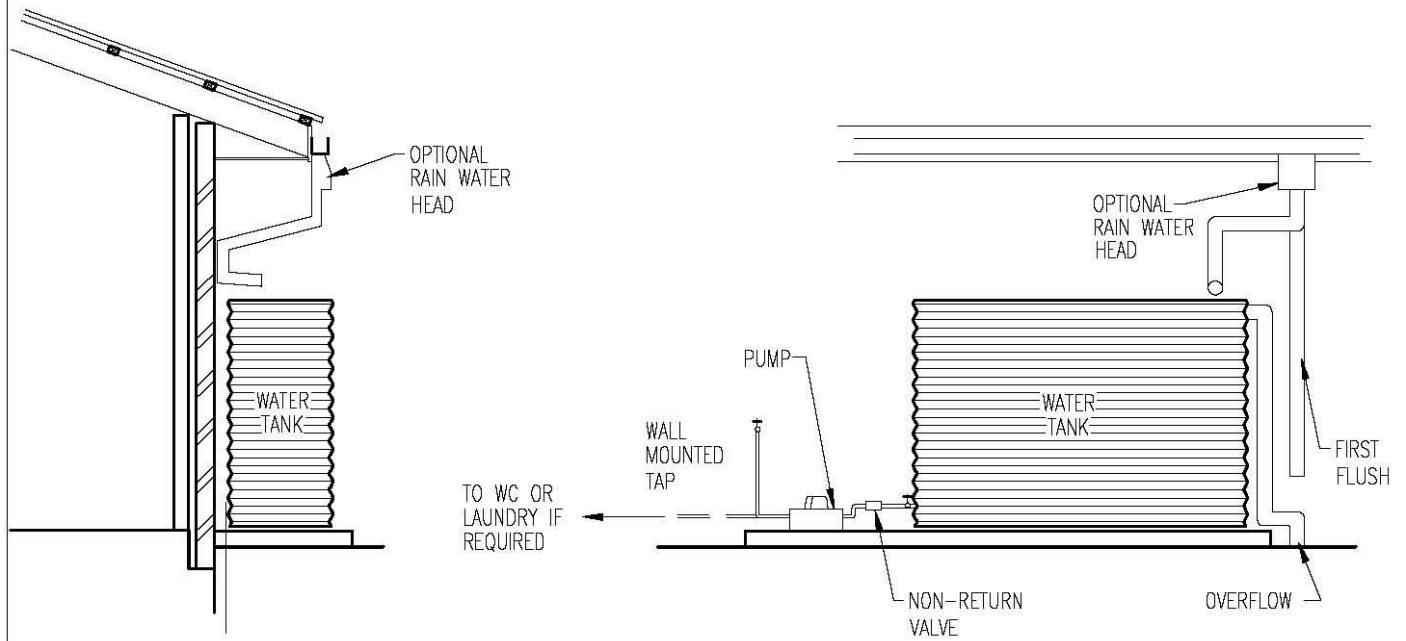

**RAIN HEAD TYPE "A"  
PLANING**

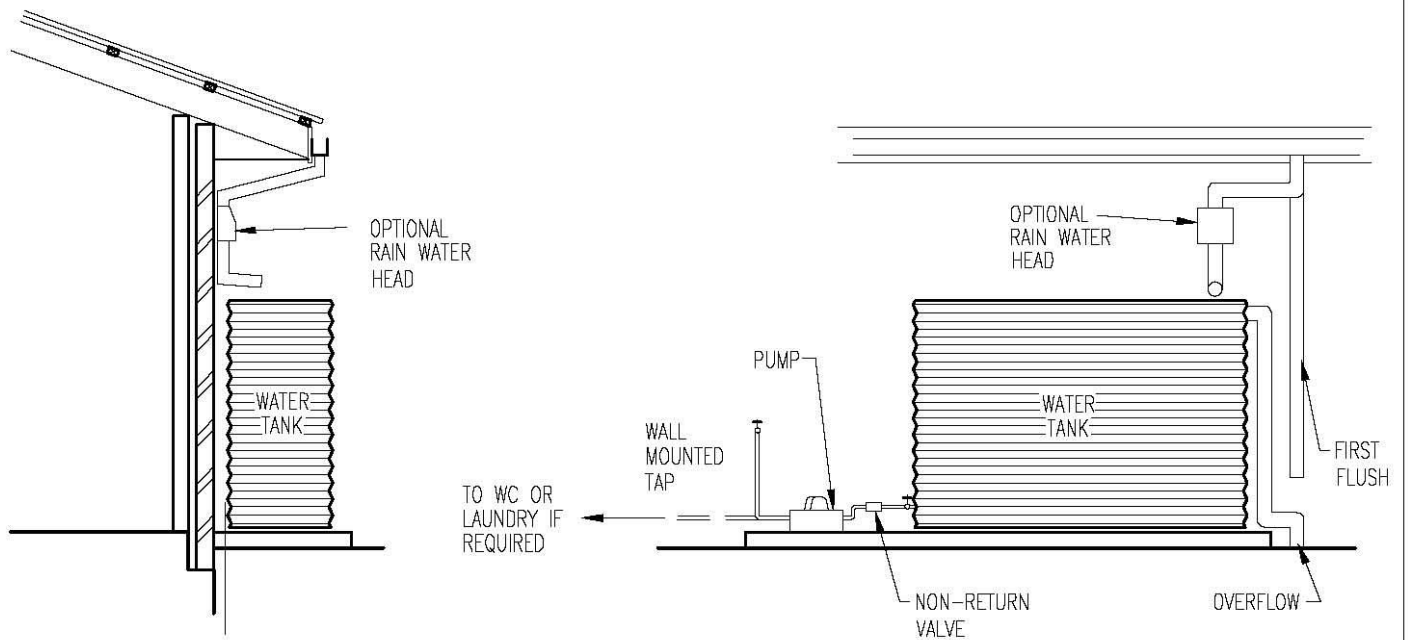

**RAIN HEAD TYPE "B"  
PLANING**

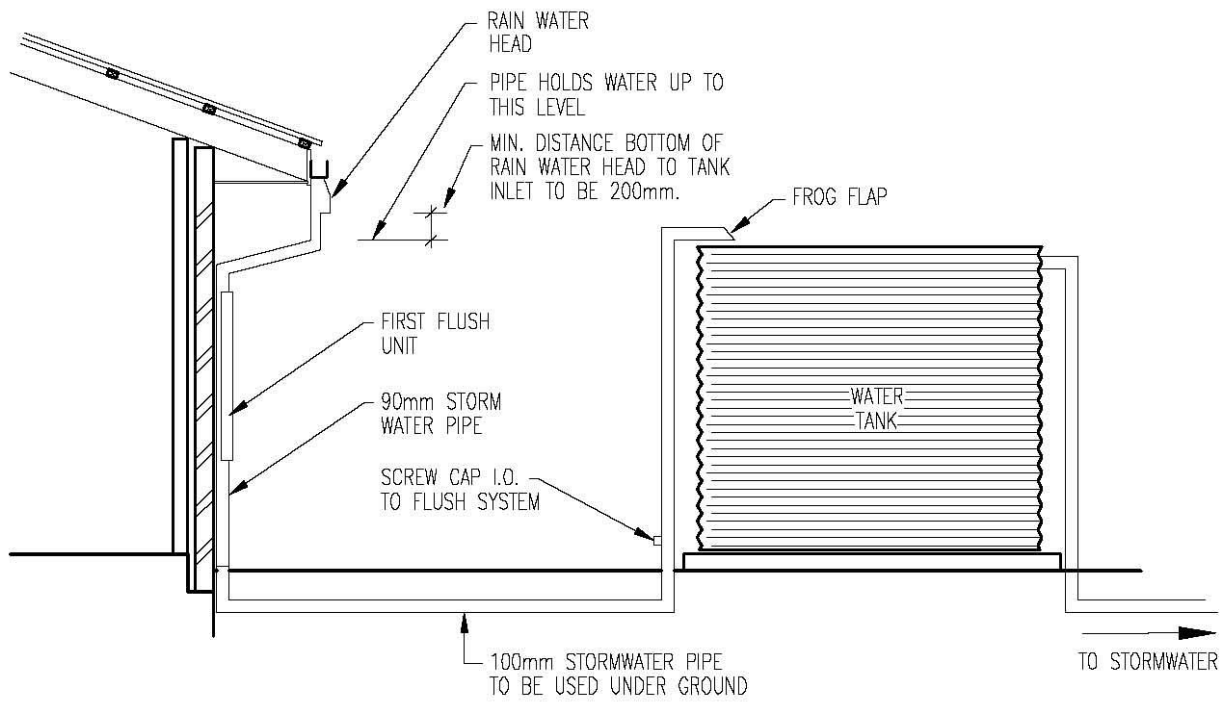

### WET CONNECTION SYSTEM

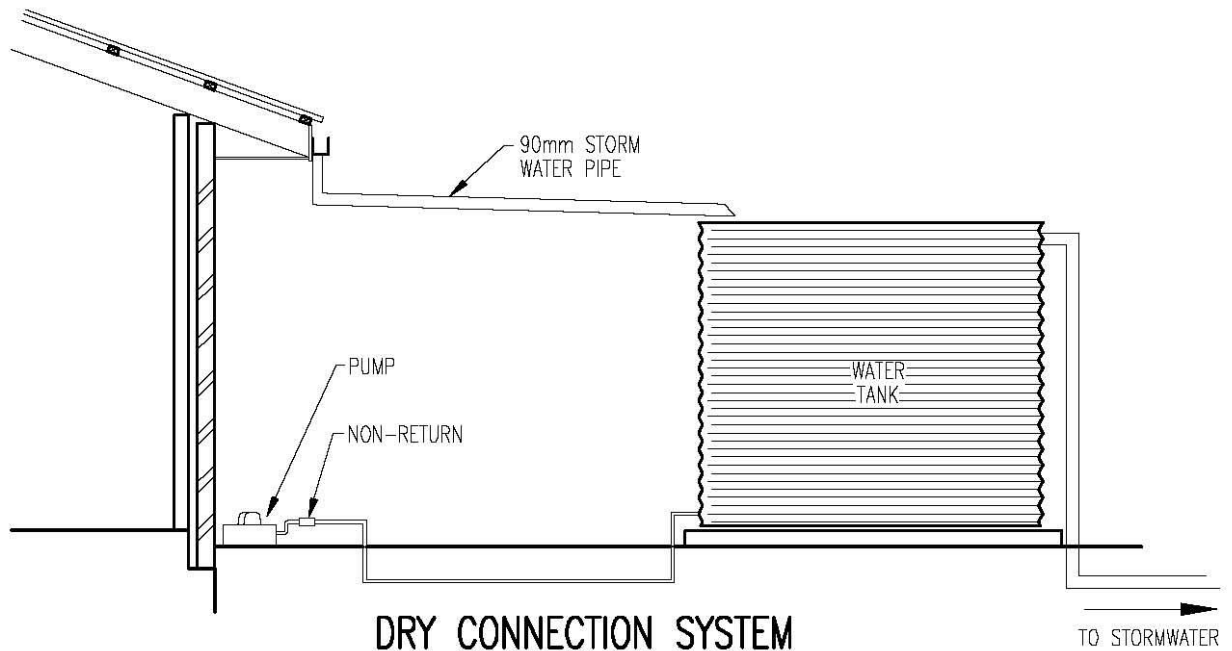

### DRY CONNECTION SYSTEM

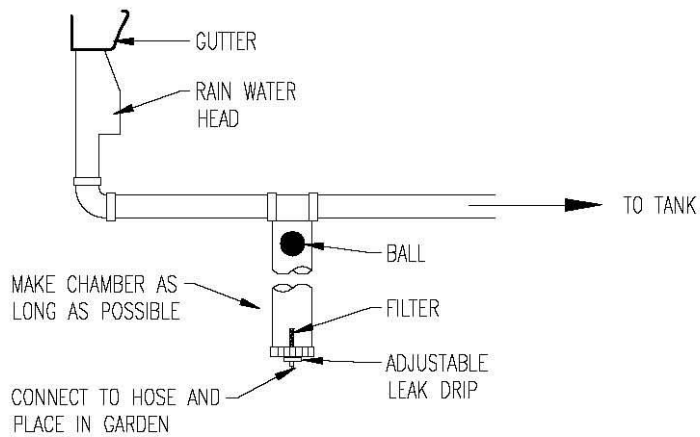

### FIRST FLUSH SYSTEM

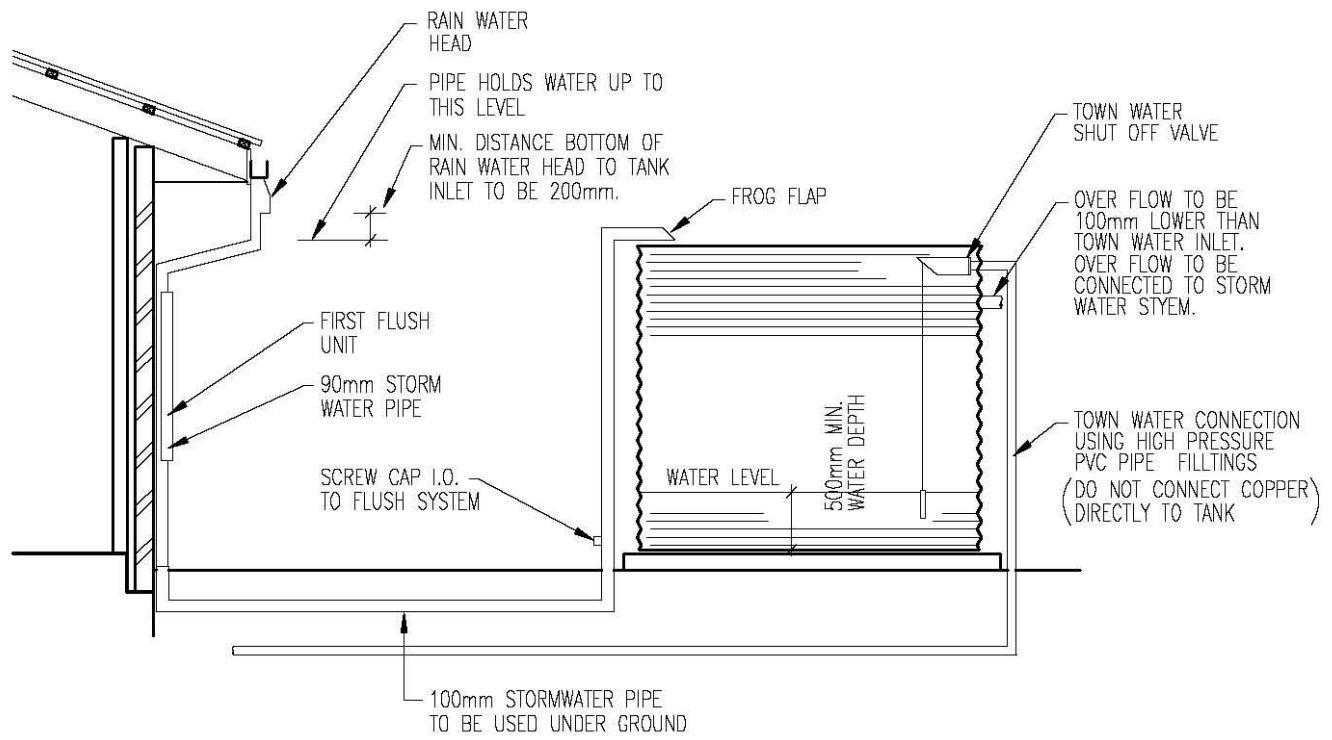

NOTE:  
 USING THIS SYSTEM WILL MEAN YOUR TANK WILL NEVER RUN OUT OF WATER.

**TOWN WATER CONNECTION WITH WET CONNECTION SYSTEM**

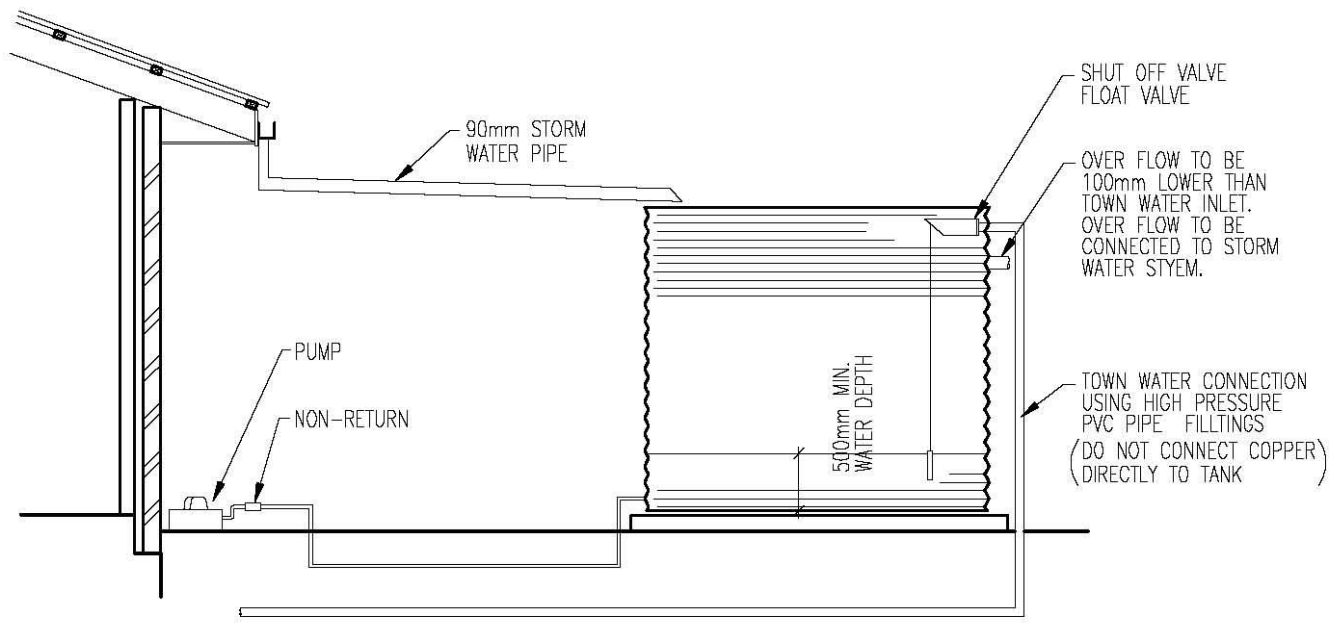

**TOWN WATER CONNECTION WITH DRY CONNECTION SYSTEM**

# MULTIPLE TANK CONNECTION

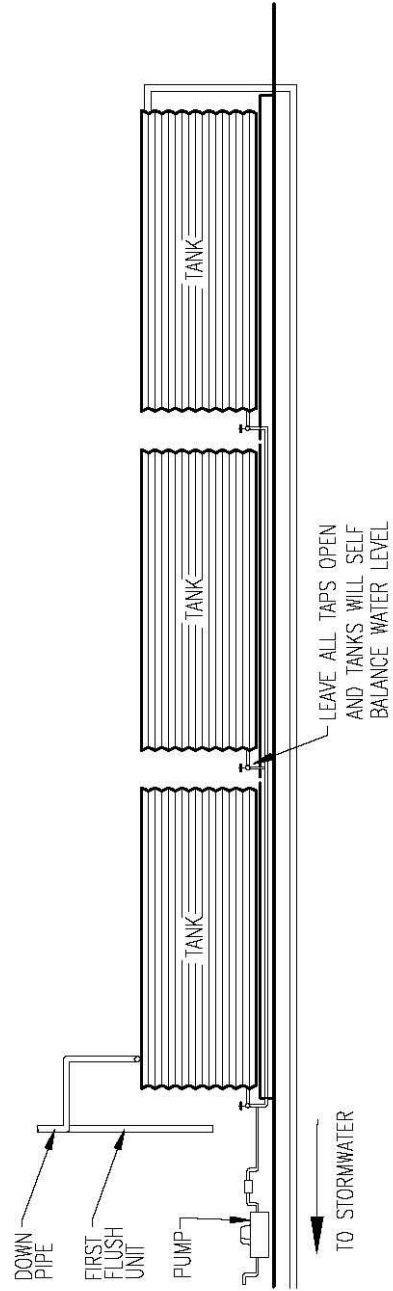

## SIDE VIEW

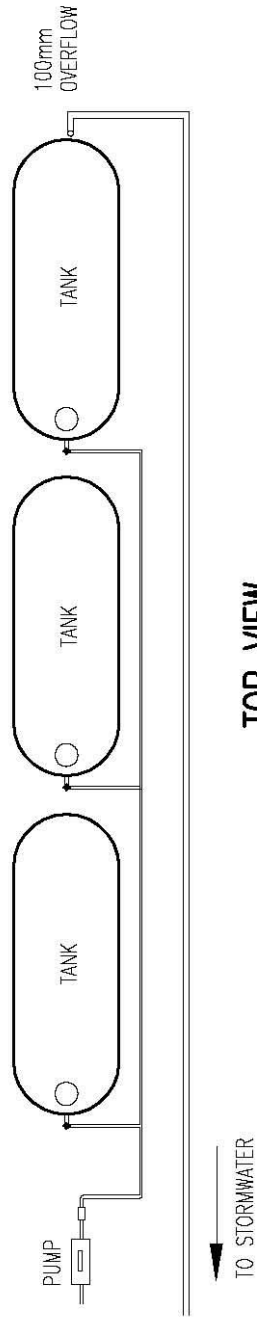

## TOP VIEW

# UNDER HOUSE WATER STORAGE SYSTEM

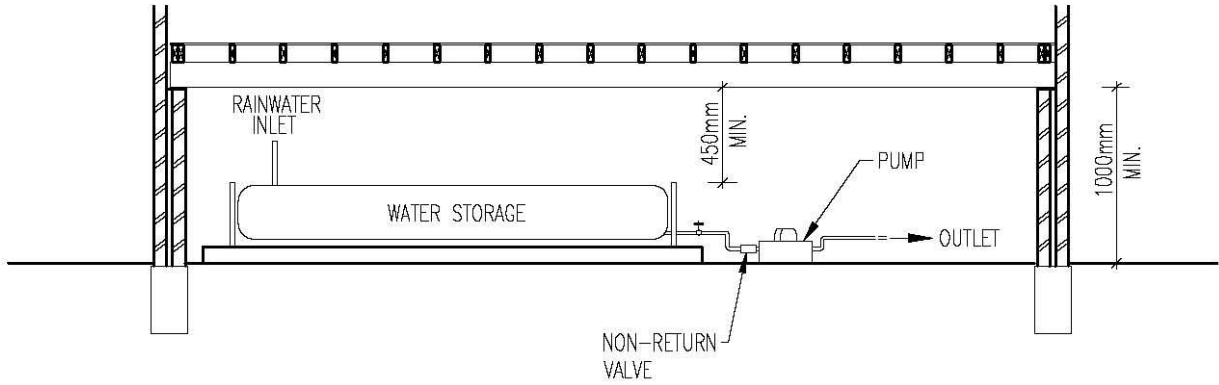

FLEXIBLE MEMBRANE WATER STORAGE  
LEVEL AREA UNDER HOUSE

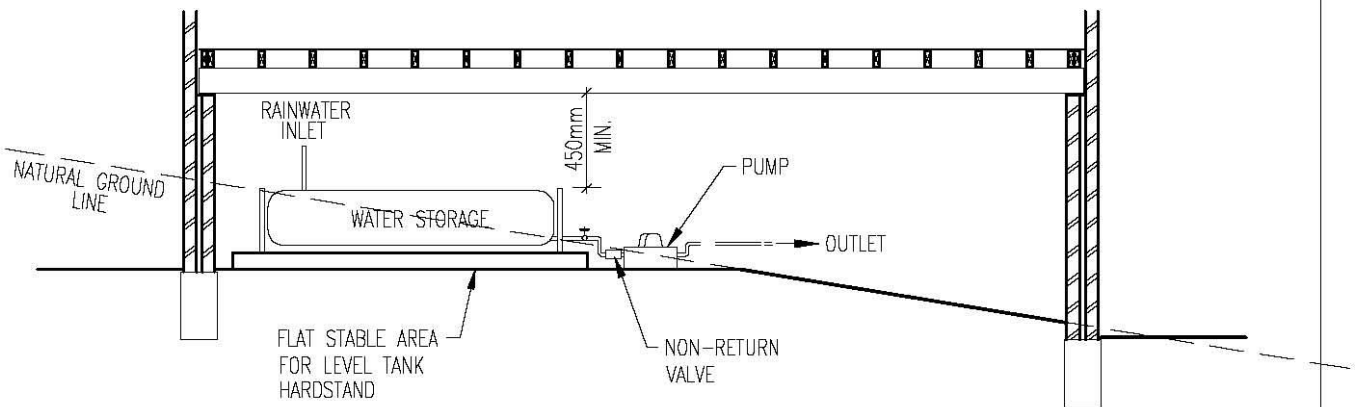

FLEXIBLE MEMBRANE WATER STORAGE  
BENCHED AREA UNDER HOUSE

## USE OF HEADER TANK TO INCREASE WATER PRESSURE

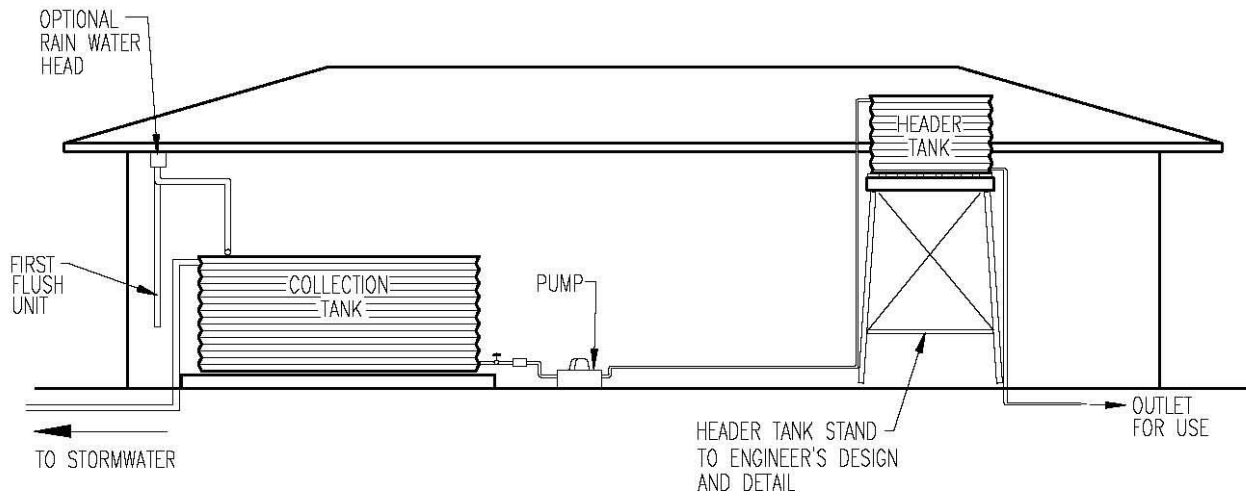

**FACT:**

TO OBTAIN TOWN WATER PRESSURE, THE HEADER TANK WOULD NEED TO BE 14 MTRS HIGH ABOVE THE KITCHEN SINK.

## WRONG WAY TO INSTALL YOUR TANK

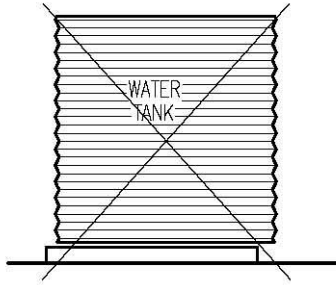

TANK BASE UNDERMINED

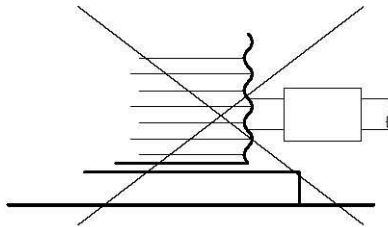

UNSUPPORTED PIPE WORK PUTS EXCESS STRAIN ON THE FITTINGS

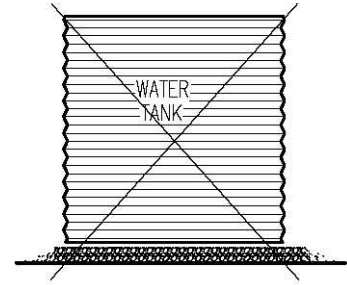

ROCKY AND UNEVEN GROUND

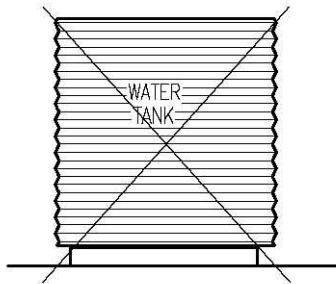

MUST NOT HAVE UNDERSIZED BASE. CIRCUMFERENCE OF TANK MUST BE SUPPORTED

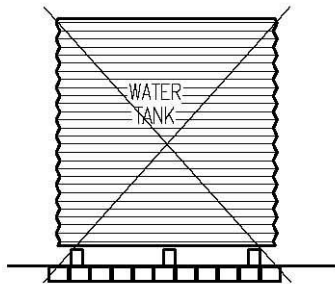

WOODEN SLEEPERS ARE GENERALLY TOO UNEVEN AND UNTRUE TO USE FOR BASE SUPPORT

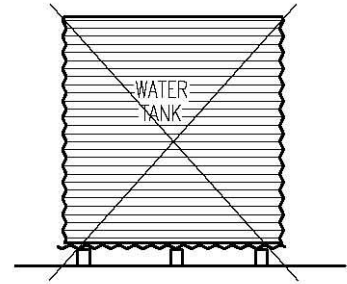

DO NOT USE CORRUGATED IRON ON TIMBER BEARERS ON THE GROUND

NOTE:  
NEVER INSTALL A WATER TANK ON A SAND BASE

IF YOU INSTALL YOUR TANK THIS WAY  
YOUR WARRANTY WILL BE VOID

## SUPPORT BASES

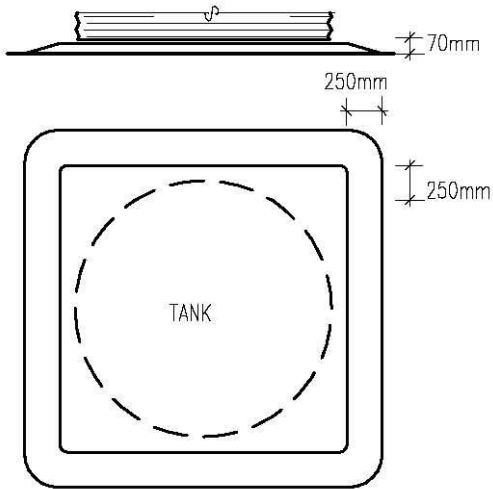

NON-RETAINED CRUSHER DUST  
SUPPORT BASE

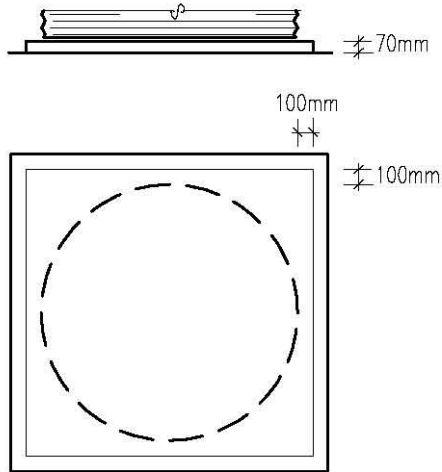

RETAINED CRUSHER DUST  
SUPPORT BASE

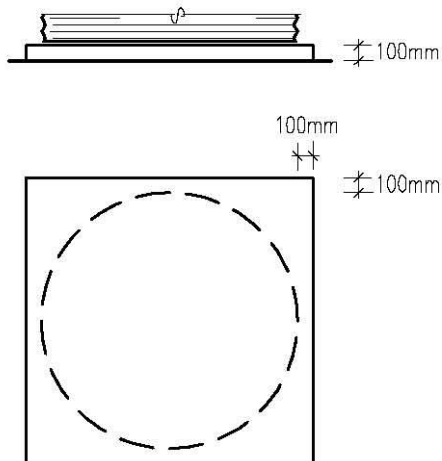

CONCRETE SLAB  
SUPPORT BASE

## TANK GROUND SUPPORT

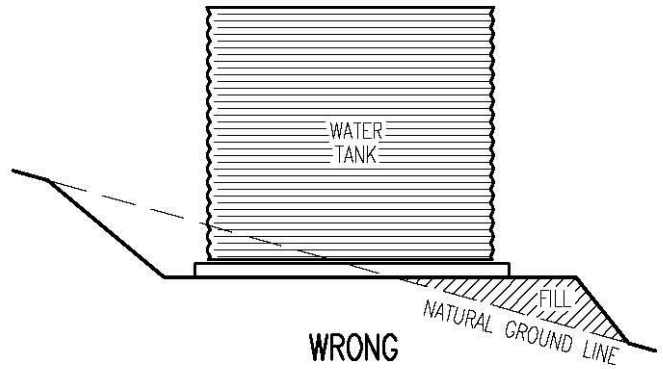

NOTE:  
WATER TANKS INSTALLED THIS WAY MAY  
VOID YOUR WARRANTY.

NEVER USE SAND AS A TANK BASE

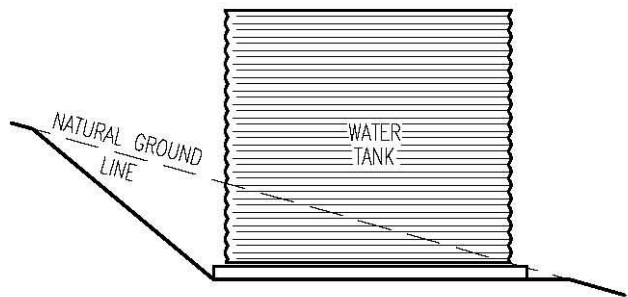

NOTE:  
SLIMLINE WATER TANKS CAN ALSO BE  
INSTALLED ON PRECAST CONCRETE SLABS  
ON A FIRM LEVEL BASE.